

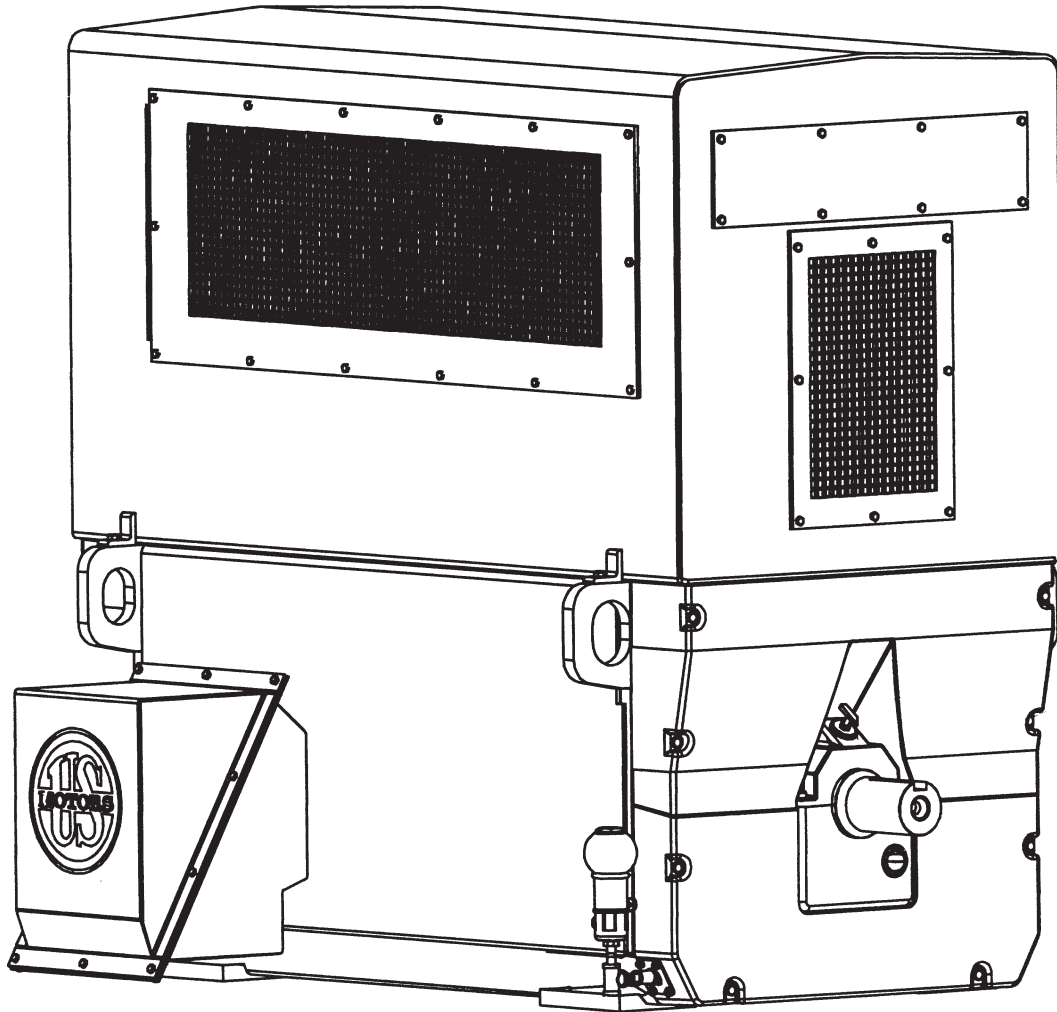

TITAN II LARGE AC ELECTRIC MOTORS



**HORIZONTAL SLEEVE BEARING, OPEN DRIPPROOF,
WPI, WPII MOTOR ENCLOSURE**

INSTALLATION, OPERATION AND MAINTENANCE MANUAL

P/N 986240

USMOTORS



SAFETY FIRST

High voltage and rotating parts can cause serious injury or loss of life. Safe installation, operation and maintenance must be performed by qualified personnel. Familiarization with and adherence to NEMA MG2, the National Electrical Code, and local codes is recommended. It is important to observe safety precautions to protect personnel from possible injury. Personnel should be instructed to:

1. Disconnect all power to motor and accessories prior to initiating any installation, maintenance or repairs.
2. Avoid contact with rotating parts.
3. Act with care in accordance with this manual's prescribed procedures in handling and installing this equipment.
4. Be sure unit and accessories are electrically grounded and proper electrical installation wiring and controls are used in accordance with local and national electrical codes. Refer to "National Electrical Code Handbook" - NFPA No. 70. Employ qualified electricians.
5. Be sure equipment is properly enclosed to prevent access by children or other unauthorized personnel in order to prevent possible accidents.
6. Be sure shaft key is fully captive before unit is energized.
7. Provide proper safeguards for personnel against rotating parts and applications involving high inertia loads which can cause overspeed.
8. Avoid extended exposure to equipment with high noise levels.
9. Observe good safety habits at all times and use care to avoid injury to yourself or damage to your equipment.
10. Be familiar with the equipment and read all instructions thoroughly before installing or working on equipment.
11. Observe all special instructions attached to the equipment. Remove shipping fixtures if so equipped.
12. Check motor and driven equipment for proper rotation and phase sequence prior to coupling. Also check if a unidirectional motor is supplied and note proper rotation.
13. Do not apply power factor correction capacitors to motors rated for operation with variable frequency drives. Serious damage to the drive will result if capacitors are placed between the motor and drive. Consult your drive supplier for more information.





SECTION	PAGE
SAFETY	i
I. SHIPMENT	1
II. HANDLING	1
III. STORAGE	2
1. When to put motor into storage	2
2. Storage Preparation	2
3. Periodic Maintenance / Insulation History	3
4. Start-up Preparations after Storage	4
IV. INSTALLATION LOCATION	5
V. FOUNDATION	5
VI. INITIAL INSTALLATION	6
1. Coupling Installation	6
2. Rough Alignment	6
3. Final Alignment	6
4. Coupling Requirements	6
5. Electrical Connection	8
6. Reversing Rotation	8
7. Initial Start	9
8. Vibration	10
VII. NORMAL OPERATION	10
1. General Maintenance	10
2. Inspection and Cleaning	10
VIII. DOWELING	11
IX. DISASSEMBLY	11
X. REASSEMBLY	14
XI. SLEEVE BEARING INSPECTION	14
XII. SLEEVE BEARING REPLACEMENT	15
XIII. LUBRICATION	16
XIV. RENEWAL PARTS AND SERVICE	17
XV. TROUBLESHOOTING	19
XVI. INSTALLATION RECORD	21





I. SHIPMENT

Prior to shipment, all Titan II Motors undergo extensive electrical and mechanical testing, and are thoroughly inspected. Upon receipt of the motor, carefully inspect the unit for any signs of damage that may have occurred during shipment. Should such damage be evident, unpack the motor at once in the presence of a claims adjuster and immediately report all damage and breakage to the transportation company and U.S Electrical Motors.

When contacting U.S Electrical Motors concerning the motor, be sure to include the complete motor identification number, frame and type which appears on the nameplate (see installation record in this manual).

⚠ CAUTION *The shaft clamping device must be in place to prevent shaft movement any time the motor is shipped. Failure to do so may result in motor bearing damage.*

II. HANDLING

The equipment needed to handle the motor includes a hoist and spreader bar arrangement of sufficient strength to lift the motor safely. The spreader bar arrangement should always be employed whenever multiple lifting lugs or eyebolts are provided (See Figure 1). The spreader bar should have the lifting hooks positioned to equal the span of the eyebolts or lifting lugs. The eyebolts or lifting lugs provided are intended to lift the motor weight only. See Table 5 for motor weights.

⚠ CAUTION

Lifting the motor by means other than specifically noted may result in damage to the motor or injury to personnel. Note that the eyebolt on the top of WPII enclosure is intended for lifting the tophat only.

FIGURE 1A

Typical Construction With Two Eyebolts

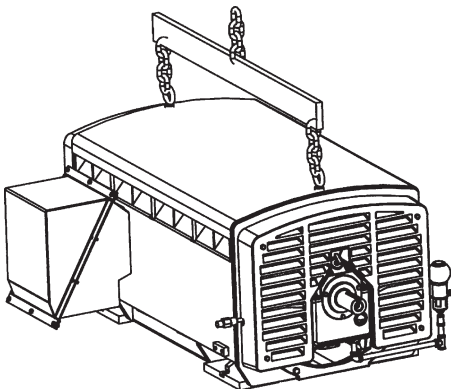
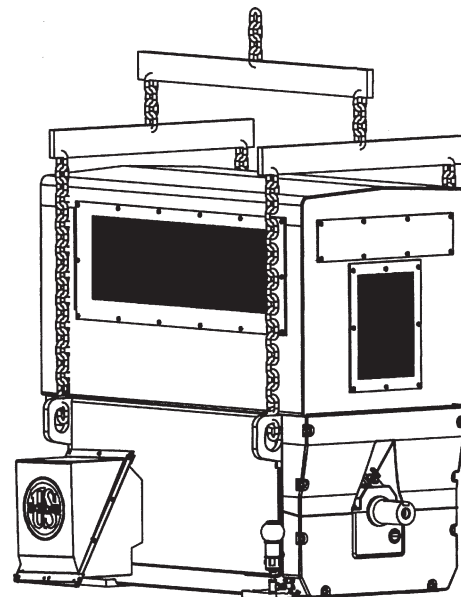

FIGURE 1B

Typical Construction With Four Lifting Lugs





III. STORAGE

1. When to put a Motor in Storage.

If a motor is not put into immediate service (one month or less), or if it is taken out of service for a prolonged period, special storage precautions should be taken to prevent damage. The following schedule is recommended as a guide to determine storage needs.

- (A) Out of service or in storage less than one month - no special precautions except that space heaters, if supplied, must be energized at any time the motor is not running.
- (B) Out of service or in storage for more than one but less than six months - store per Items 2 A through 2F, 2H, 3 and 4.
- (C) Out of service or in storage for six months or more - all recommendations.

2. Storage Preparation.

- (A) Where possible, motors should be stored indoors in a clean, dry area.
- (B) When indoor storage is not possible, the motors must be covered with a tarpaulin. This cover should extend to the ground. Do not tightly wrap the motor as this will restrict air flow and result in surface condensation. Care must also be taken to protect the motor from flood damage or from any harmful chemical vapors.
- (C) Whether indoors or out, the area of storage should be free from excessive vibration which can cause bearing damage.
- (D) Precautions should be taken to prevent rodents, snakes, birds, or other small animals from nesting inside the motors. In areas where they are prevalent, precautions must also be taken to prevent insects, such as mud dauber wasps, from gaining access to the interior of the motor.
- (E) Inspect the rust preventative coating on all external machined surfaces, including shaft extensions. If necessary, recoat the surfaces with a rust preventative material such as Rust Veto No. 342 (manufactured by E. F. Houghton Co.) or an equivalent. The condition of the coating should be checked periodically and surfaces recoated as needed.
- (F) To prevent moisture accumulation, some form of heating must be utilized to prevent condensation. This heating should maintain the winding temperature at a minimum of 5° C above ambient. If space heaters are supplied, they should be energized. If none are available, single phase or "trickle" heating may be utilized by energizing one phase of the motor winding with a low voltage. Request the required voltage and transformer capacity from U.S. Electrical Motors. A third option is to use an auxiliary heat source too keep the winding warm by either convection or blowing warm air into the motor.
- (G) Drain oil from both bearing housings and refill with a circulating type oil such as Mobil Vaprotec, Enlulob 453 (available from Engineered Lubricants) or equivalent. Oil should be changed every 12 months while motor is in storage.
- (H) All motors must have shaft rotated a few turns once a month to maintain a lubricant film on the shaft bearing journals.





3. Periodic Maintenance/Insulation History:

The only accurate way to evaluate the condition of the winding insulation is to maintain a history of the insulation readings. Over a period of months or years these readings will tend to indicate a trend. If a downward trend develops or if the resistance drops too low, thoroughly clean and dry the windings, retreating if necessary.

The recommended insulation resistance test is as follows:

- (A) Using a megohmmeter, with winding at ambient temperature, apply DC voltage (noted below) for 60 seconds and take reading.

<u>Rated Motor Voltage</u>	<u>Recommended DC Test Voltage</u>
600 and less	500 VDC
601 to 1000 incl.	500 to 1000 VDC
1001 and up	500 to 2500 VDC (2500 VDC optimum)

- (B) For comparison the reading should be corrected to a 40°C base temperature. This may be done by utilizing the following:

$$R_{40C} = K_t \times R_t$$

Where R_{40C} = insulation resistance (in megohms) corrected to 40°C

R_t = measured insulation resistance (in megohms)

K_t = temperature coefficient (from Graph 1)

GRAPH 1

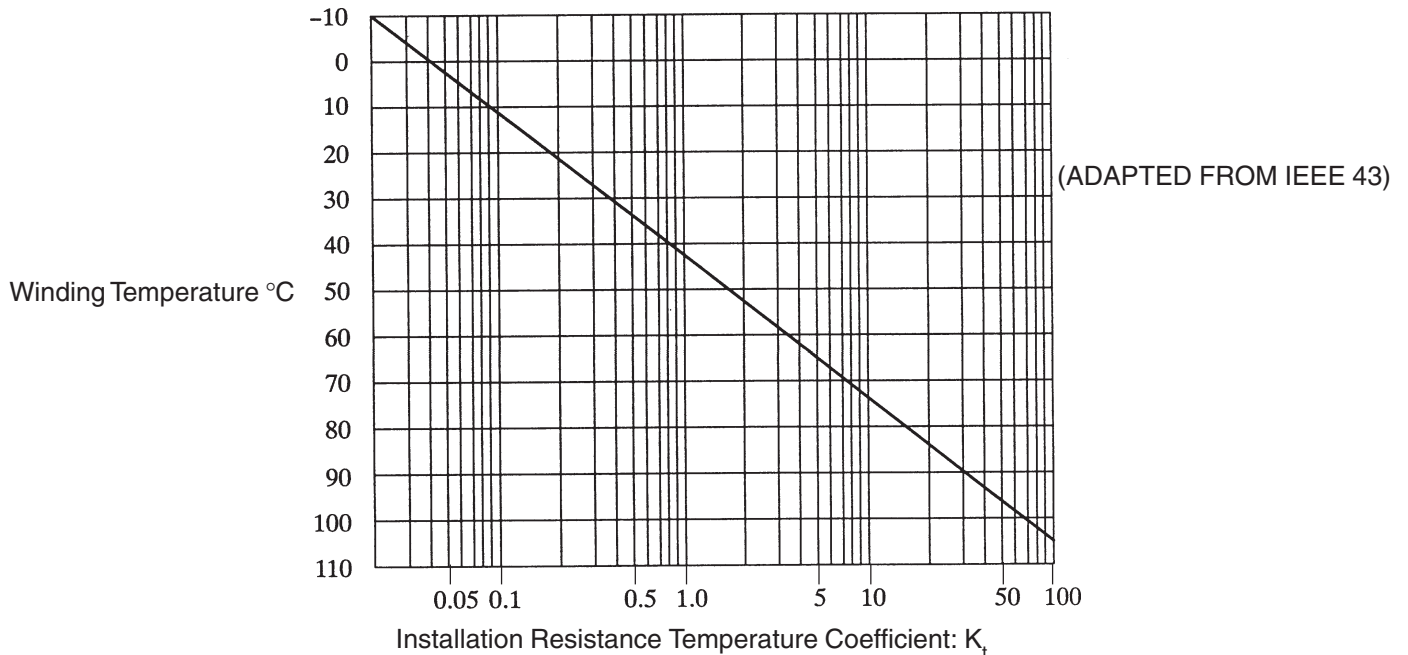



(C) Insulation resistance readings must not drop below the value indicated by the following formula:

$$R_m = K_v + 1$$

R_m = minimum insulation, in megohms, at 40°C
 K_v = rated motor voltage in kilovolts

(D) Dielectric Absorption Ratio:

In addition to the individual test reading, a dielectric absorption ratio may be required. The dielectric absorption ratio is obtained by taking megohmmeter readings at a one minute and ten minute interval or when hand powered megohmmeters are used, at a thirty second and sixty second interval. The voltage should be the same as outlined in Part A of this procedure.

The ratio is obtained by dividing the second reading by the first reading and is based on a good insulation system increasing its resistance when subjected to a test voltage for a period of time. The ratios are as follows:

<u>10 minute : 1 minute</u>		<u>60 second : 30 second</u>	
Dangerous	= less than 1.0	Poor	= less than 1.1
Poor	= 1.0 to 1.4	Questionable	= 1.1 to 1.24
Questionable	= 1.5 to 1.9	Fair	= 1.25 to 1.3
Fair	= 2.0 to 2.9	Good	= 1.4 to 1.6
Good	= 3.0 to 4.0	Excellent	= Over to 1.6
Excellent	= Over 4.0		

If a low insulation resistance reading is obtained in either the individual test or dielectric absorption ratio test, thoroughly clean and dry the windings. Recheck insulation resistance and dielectric absorption ratio.

NOTE: Slightly lower dielectric absorption ratios may be acceptable when high initial insulation resistance readings are obtained (1,000 + megohms). Refer any questions to U.S.E.M. Service Department.

For additional information on insulation testing, refer to IEEE Transaction No. 43.

4. Start-up Preparations after Storage.

- (A) Motor should be thoroughly inspected and cleaned to restore to an "As Shipped" condition.
- (B) If motor has been in storage for up to one year, remove the drain plugs from the bearing housing and drain all storage oil. If any moisture is present, disassemble the bearing from the bracket and inspect the bearing journals for any damage as described in **Section IX. Disassembly and Section X. Reassembly**. Flush out bearing housing with clean oil and fill to proper level using a high quality oil from Table 3.
- (C) The winding must be tested to obtain insulation resistance and dielectric absorption ratio as described in Part 3 of this section.
- (D) If storage has exceeded one year, the U.S.E.M. Quality Assurance Department must be contacted prior to equipment start-up.





IV. INSTALLATION LOCATION

When selecting a location for the motor and driven unit, keep the following items in mind:

1. The location should be clean, dry, well ventilated, properly drained and provide accessibility for inspection, lubrication, and maintenance. Ambient vibration should be kept to a minimum. Outdoor installations on Open Dripproof motors require protection from the elements.
2. The location should also provide adequate space for motor removal without shifting the driven unit.
3. The temperature rise of a standard motor is based on operation at an altitude not higher than 3,300 feet above sea level. See NEMA MG-1 20.40 for normal service condition.
4. To avoid condensation inside of motor, motors should not be stored or operated in areas subject to rapid temperature changes unless they are energized or protected by space heaters.
5. The motor should not be installed in close proximity to any combustible material or where flammable gases and/or dust may be present, unless motor is specifically built for that environment and is U. L. labeled accordingly.

V. FOUNDATION

Concrete (reinforced as required) makes the best foundation, particularly for large motors and driven units. A sufficient mass provides rigid support that minimizes deflection and vibration. It may be located on soil, structural steel, or building floors, provided the total weight (motor, driven unit and foundation) does not exceed the allowable bearing load of the support. (Allowable bearing loads of structural steel and floors can be obtained from engineering handbooks; building codes of local communities give the recommended allowable bearing loads for different types of soil). It is recommended that a fabricated steel base (sole plate) be used between motor feet and foundation. See Figure 2. Base foot pads should be level and in the same plane.

Grouting

Grouting is the process of firmly securing equipment to a concrete base. This base is a continuation of the main foundation, designed to dampen any machine vibration present and prevent the equipment from shaking loose during operation. A serviceable and solid foundation can be laid only by careful attention to proper grouting procedure.

In practical terms, "grout" is a plastic filler which is poured between the motor sole plate and the foundation upon which it is to operate. Being plastic, it is expected to fill all spaces and cavities before it sets or solidifies and becomes an integral part of the principal foundation. In order to function properly, the principal foundation should be allowed to fully set through chemical reaction and dehydration as recommended by the grout manufacturer, prior to motor installation.

FIGURE 2
TYPICAL MOTOR
MOUNTING
ARRANGEMENT

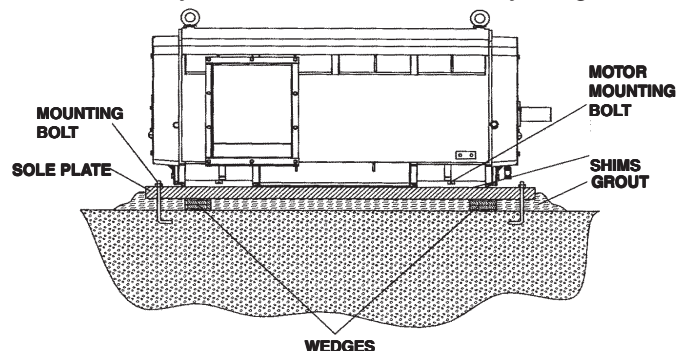



VI. INITIAL INSTALLATION

1. Coupling Installation

Remove the shaft clamping device shipped on motor. Do not discard the clamping device as it will be needed should the motor require transport in the future. Wash protective coating from the motor shaft extension(s) with solvent. Install couplings on motor shaft per manufacturers' recommended fit and mounting practices.

▲ Caution *Sleeve bearing motors should be direct coupled to the driven equipment. See coupling recommendations for recommended coupling type. Never use a pulley or sprocket as they transmit unacceptable radial loads to the motor bearings.*

2. Rough Alignment

Inspect sole plate mounting pads and bottom of motor feet for dirt or irregularities that would prevent proper seating.

Position and shim the motor such that the coupling hubs are aligned within 1/32" and the motor shaft is level. The motor shaft must be slightly lower than the driven shaft to allow for final adjustment shims. Shims and support mounting should provide support under the entire foot area.

3. Final Alignment

Accurate shaft alignment between motor and driven equipment is essential for trouble-free operation. Improper alignment can result in vibration, bearing overload and excessive shaft stresses. Flexible couplings may not adequately compensate for excessive misalignment.

Whenever aligning a motor to driven equipment, keep the following rules in mind:

- Do not place more than five shims in a shim pack under any one machine foot, as the flexibility of the shim pack will contribute to a soft foot condition.
- After any corrective adjustment, tighten foot bolts securely and recheck alignment.
- When making shim adjustments, change only one foot at a time.
- Recheck alignment after the motor has been in service for approximately one week and readjust as necessary.

A. Angular Alignment (See Figure 3A)

Check for angular misalignment of motor to driven unit shaft. (See Figure 3A). Measure distance between coupling hub faces (with feeler gauges) at four places equally spaced around the outside diameters. Position motor as necessary to be within the maximum allowable misalignment of .001 in. per foot of coupling radius.

B. Parallel Alignment (See Figure 3B)

Fasten a dial indicator onto one coupling hub with the indicator button on the cylindrical surface of the opposite coupling hub. Rotate shafts together and take readings at four points, 90° apart. Relocate motor until total indicator movement in full rotation does not exceed .002". Transfer indicator to opposite hub and repeat the parallel alignment procedure. Recheck angular alignment as described in Step A.





FIGURE 3 FLEXIBLE COUPLINGS

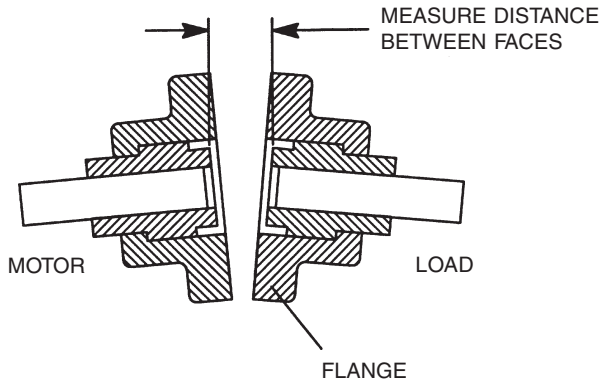

FIGURE 3A FLEXIBLE COUPLINGS ANGULAR ALIGNMENT

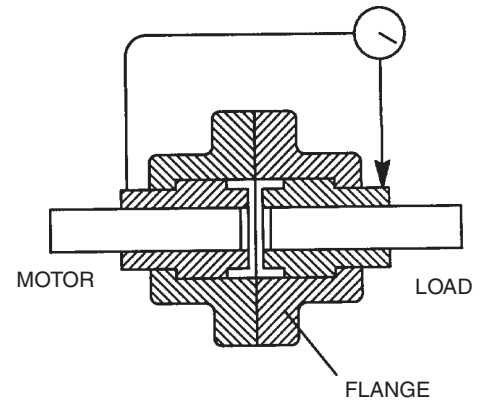

FIGURE 3B FLEXIBLE COUPLINGS PARALLEL ALIGNMENT

C. Soft Foot Check

Check and correct any "soft foot" condition to assure that equal pressure is exerted on each motor foot by the following shimming procedure. Bolt all motor feet down solidly to the motor bedplate or foundation. Mount the base of the dial indicator from the motors foundation, and place and zero out the indicator on the motor shaft or coupling. Back off one of the take off end bolts and check indicator for change in reading, a .001 inch reading is maximum. Shim at foot if required and go to other take off end bolt. This procedure should be repeated on the opposite end until no reading is greater than .001 inches.

D. Hot Alignment

It is possible for motor shaft height to change relative to the driven equipment and this should be compensated for during the alignment procedure. Recheck parallel alignment (vertical) of coupled drive by repeating after normal operating temperature is reached. If shimming is changed, repeat alignment procedure to the extent necessary to assure proper alignment.

4. Coupling Requirements

Standard sleeve bearing motors are not designed to withstand axial thrust loads. Machines that are to be driven by motors with sleeve bearings should be designed to take all the thrust load. The driven equipment shaft should have its axial end play limited as necessary to prevent applying any axial loads to the motor sleeve bearings.

Operating experience on horizontal sleeve bearing motors has shown that sufficient thrust to damage bearings may be transmitted to the motor through some flexible couplings. This requires that limited end float couplings, in accordance with the following be used.

- | | |
|----------------------|------------------------|
| A. Gear Type | C. Roller Chain Type |
| B. Tapered Grid Type | D. Rubber Biscuit Type |





FIGURE 4

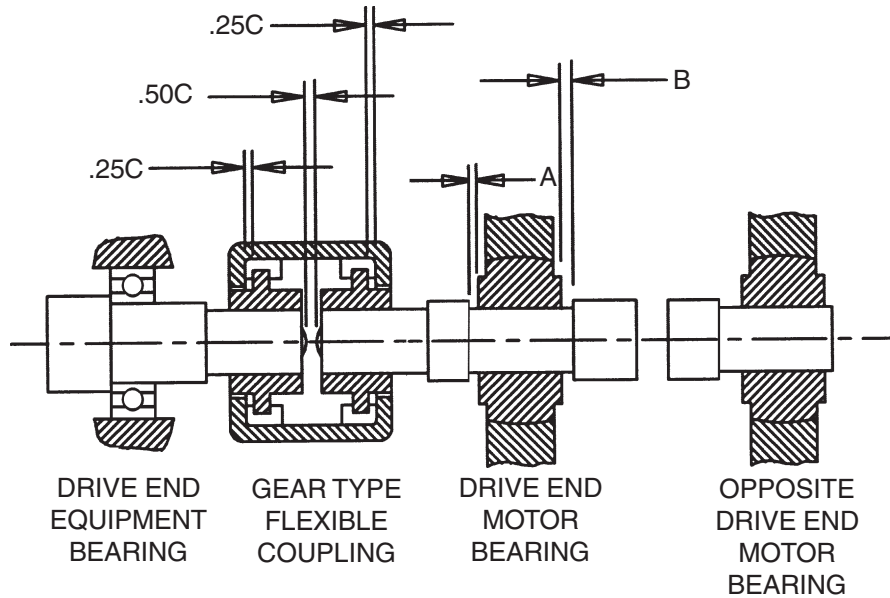

A + B = TOTAL MIN ROTOR END FLOAT
C = TOTAL MAX COUPLING END FLOAT

TABLE 1 -- COUPLING END PLAY AND ROTOR FLOAT
(Adapted from NEMA MG1-20.81)

MOTOR HP	SYNCHRONOUS SPEED OF MOTOR, RPM	TOTAL MINIMUM MOTOR ROTOR END FLOAT (IN.)	TOTAL MAXIMUM COUPLING END FLOAT (IN.)
500 & Below	1800 & Below	0.25	0.09
300 to 500 included	3600 & 3000	0.50	0.19
600 & Higher	All Speeds	0.50	0.19

5. Electrical Connection

Refer to the motor nameplate for power supply requirements and to the connection diagram for connection parameters. Be sure connections are tight. Recheck carefully and assure that they agree with the connection diagram. Insulate all connections with electrical tape to insure that they will not short against each other or to ground. Be sure the motor is grounded to guard against electrical shock. Refer to the National Electrical Code Handbook (NFPA No. 70) and to local electrical codes for proper wiring, protection, and wire sizing. Be sure proper starting equipment and protective devices are used for every motor. For assistance, contact the motor starter manufacturer. Apply the above precautions to all accessories as well.

6. Reversing Rotation

The direction of rotation may be reversed by interchanging any two, of the three power phases to the motor leads. Be sure that the power is off and steps are taken to prevent accidental starting of the motor before attempting to change any electrical connections.





⚠ CAUTION

Some motors have unidirectional ventilating fans. Running such a unit in reverse for any extended length of time will result in motor damage. On motors that are unidirectional, the direction of rotation is noted by an arrow mounted above the take-off-shaft and by a warning plate mounted near the main nameplate. To determine direction of rotation for which leads are connected, apply power momentarily and observe rotation. Motor should be uncoupled from driven equipment to insure driven equipment is not damaged by reverse rotation. Couplings may require removal or support if motor is operated uncoupled from the driven equipment.

7. Initial Start

After installation is completed, but before motor is put in regular service, make an initial start as follows:

- A. Insure that motor and control device connections agree with wiring diagrams.
- B. Insure that voltage, phase and frequency of line circuit (power supply) agree with motor nameplate.
- C. Check insulation resistance according to **Section III. "Storage", Part 3.**
- D. Check all foundation and base bolts to insure that they are tight.
- E. If motor has been in storage, either before or after installation, refer to **Section III. "Storage", Part 4** for preparations.
- F. Check for proper or desired rotation. See Part 6 of this section.
- G. Insure that all protective devices are connected and are operating properly.
- H. Run motor at minimum possible load long enough to be certain that no unusual condition develops. Listen and feel for excessive noise, vibration, clicking or pounding. If any are present, stop motor immediately. Investigate the cause and correct before putting motor into service. In the case of vibration, see Part 7 of this section.
- I. Check sleeve bearing housings to be certain that they have been filled to the "MAX" level with the correct lubricant recommended in the instruction manual and lubrication plate.

⚠ CAUTION

Repeated trial starts can overheat the motor (particularly for across-the-line starting) or the external starting equipment. If repeated trial starts are made, allow sufficient time between starts to permit heat to be dissipated from windings and controls to prevent overheating. Refer to Starting Duty Nameplate (if supplied) and NEMA MG1-12.54, MG1-20.42 and MG1-20.43 for allowable starting frequency and load inertia (WR^2).

- J. When checks are satisfactory to this point, increase the load slowly up to rated load and check unit for satisfactory operation.





7. Vibration

Motors are supplied as standard in accordance with NEMA MG-1, section 7, which dictates that motor no-load vibration when mounted on a resilient base shall not exceed the limits as outlined in the following table:

TABLE 2
NO-LOAD VIBRATION LIMITS

Speed, RPM	Rotational Frequency, Hz	Velocity, Inches per second peak
3600	60	0.15
1800	30	0.15
1200	20	0.15
900	15	0.12
720	12	0.09
600	10	0.08

If vibration is deemed excessive, check for and correct any misalignment and/or "soft foot" condition per part 3 of this section.

VII. NORMAL OPERATION

Start the motor in accordance with standard instructions for the starting equipment used. Connected load should be reduced to the minimum, particularly for reduced voltage starting and/or high inertia connected loads, until the unit has reached full speed.

1. General Maintenance

Routine maintenance is the best assurance of trouble-free motor operation; it prevents costly shutdown and repairs. Major elements of a controlled maintenance program include:

- A. Trained personnel who KNOW the work.
- B. Systematic records, which contain at least the following:
 - 1. Complete nameplate data.
 - 2. Prints (wiring diagrams, certified outline dimensions).
 - 3. Alignment data (departures from perfect alignment, allowance for temperature).
 - 4. Winding resistance and temperature.
 - 5. Results of regular inspection, including vibration and bearing temperature data as applicable.
 - 6. Documentation of any repairs.
 - 7. Lubrication data (method of application, type of lubricant used, maintenance cycle by location).

2. Inspection & Cleaning

Stop the motor before cleaning. (**CAUTION: See section on safety, page i**). Clean the motor, inside and outside, regularly. The frequency depends upon actual conditions existing around the motor. Use the following procedures, as they apply:

- A. Wipe any contaminants from external surfaces of the motor.





- B. Remove dirt, dust, or debris from ventilating air inlets. Use compressed air as necessary. Never allow dirt to accumulate near air inlets. Never operate motor with air passages blocked or restricted.

⚠ CAUTION

When using compressed air, always use proper eye protection to prevent accidental eye injury.

- C. Filters in weather protected top hats should be removed and cleaned per filter manufacturer's recommendations.
- D. Clean motors internally by vacuuming or blowing with clean, dry compressed air. Generally a pressure not exceeding 30 PSI is recommended.
- E. When dirt and dust are solidly packed, or windings are coated with oil or greasy grime, disassemble the motor and clean with solvent. Use only high-flash naphtha, mineral spirits, or Stoddard solvent. Wipe with solvent-dampened cloth, or use suitable soft bristle brush. **DO NOT SOAK.** Oven dry (150 - 175° F) solvent cleaned windings thoroughly before reassembly.
- F. After cleaning and drying the windings, check the insulation resistance. Refer to **Section III., Part 3** for procedure.

VIII. DOWELING

Doweling the motor (and driven unit) accomplishes the following:

- 1. Restricts movement of the motor and driven unit.
- 2. Eases realignment if motor is removed from base.
- 3. Temporarily restrains the motor, should mounting bolts loosen.

The following procedure for inserting dowel pins is recommended (See Figure 7A, 7B).

- 1. Check the alignment after the unit has been in operation approximately one week. Correct if necessary.
- 2. Drill through motor feet on drive end and into base. Use holes in motor feet as a pilot. Drill diameter must be slightly smaller than the intended dowel size to allow for reaming operation.
- 3. Ream holes in the feet and base to the proper diameter for the pins (light press fit). Clean out the chips.
- 4. Insert dowel pins.

IX. DISASSEMBLY

See Figure 5 for Bearing Housing Cross Section.

- A. Disconnect power and assure against accidental starting of motor.
- B. Unbolt and remove end grills or shrouding.
- C. To remove filters on weather protected units for inspection and cleaning, remove end cover and rotate latch. Slide filter out of tophat assembly.
- D. Remove screws from inner shaft seals.
- E. Unbolt outer shaft seal, cover plate (opposite shaft end) and remove with their gaskets.





Bearing caps are not interchangeable and have been identified to allow installation on the same bracket from which they are removed.

- F. Remove all thermostats, probes, thermocouples, etc. from bearings and brackets.
- G. Disconnect vent tube from inner seal. Remove bolts that hold inner seal. Unbolt and remove bearing caps.
- H. Unbolt and remove upper halves of bearings.

⚠ CAUTION *The upper halves of the bearing are not interchangeable and must be installed on the same lower halves from which they are removed.*

For insulated bearing(s), care should be exercised to prevent damage to the insulating coating while installing, removing, or handling the bearing.

- I. Raise the motor shaft approximately 1/32 inch. The takeoff end of the shaft can be lifted by placing a sling directly around the shaft extension. The end of the shaft opposite the takeoff end can be lifted by threading a bolt or eyebolt into the threaded hole in the end of the shaft and placing the sling around it. Once the shaft is raised, rotate the lower halves of the bearing cartridges out from under the shaft.

⚠ CAUTION *Raising the shaft beyond the free movement of the rotor will damage the shaft, rotor or stator.*

- J. Remove the oil rings.
- K. Drain oil from bracket reservoirs.
- L. Remove bolts holding brackets to frame and remove brackets.
- M. Slide the bushing and inner seals off the shaft.
- N. Remove rotor from stator.
- O. If the atmosphere is corrosive or the motor will be disassembled for an extended length of time, protect all motor parts as necessary to prevent rust, damage or accumulation of dirt or moisture.
- P. For reassembly, see **Section X. Reassembly**.





**FIGURE 5
TYPICAL SLEEVE BEARING CONSTRUCTION**

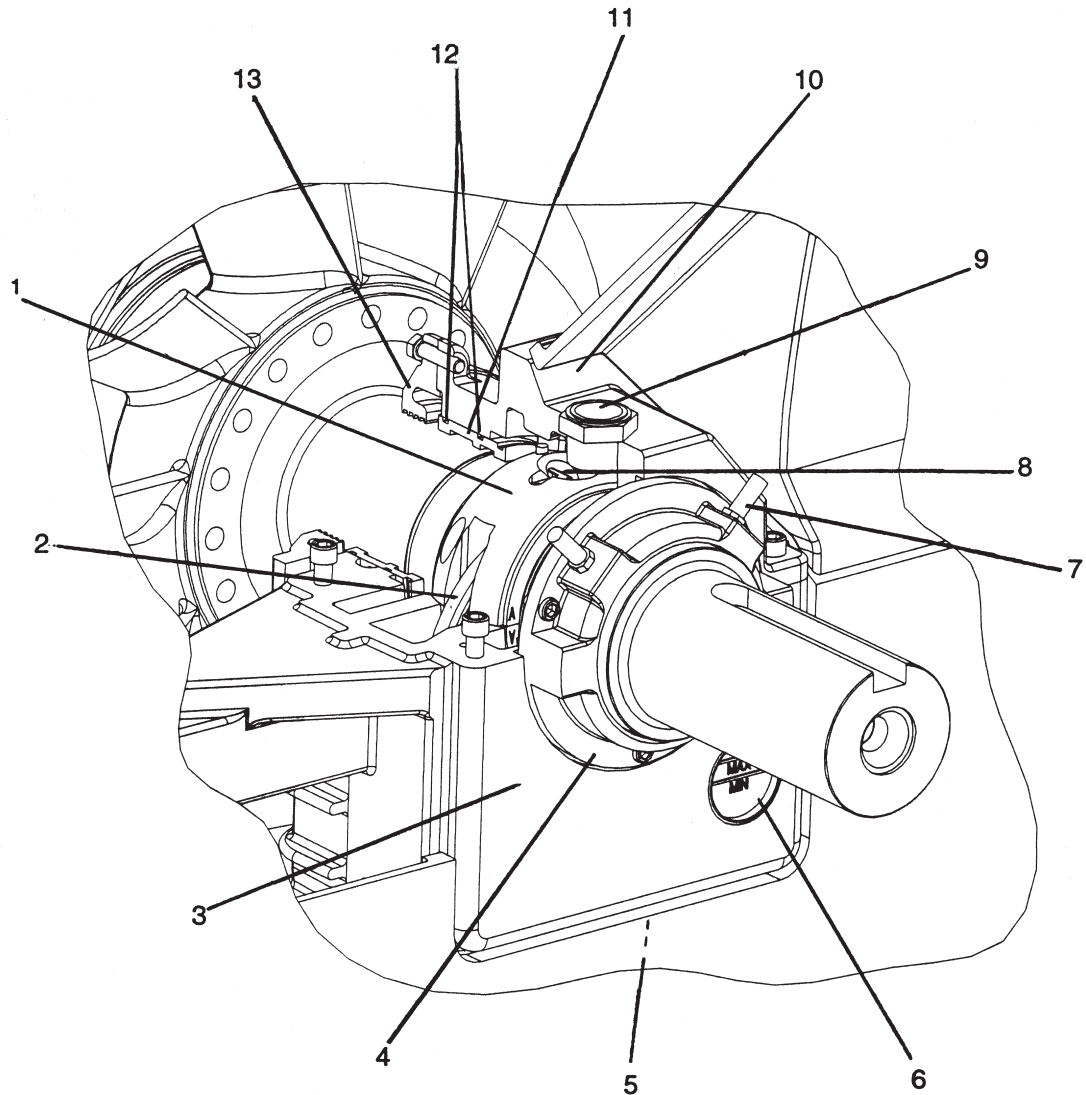

- | | |
|---------------------------------|---------------------------------|
| 1. 2 piece Babbit-Lined Bearing | 8. Oil Ring Guide |
| 2. Oil Ring | 9. Oil Fill and Inspection port |
| 3. Lower Bracket | 10. Bearing Cap |
| 4. Outer Bearing Seal | 11. Bearing Bushing |
| 5. Oil Drain | 12. O Ring Seals |
| 6. Oil level Sight Glass | 13. Inner Bearing Seal |
| 7. Optional Proximity Probes | |





X. REASSEMBLY

⚠ CAUTION *When reassembling all fasteners should be torqued to the values shown in Table 5 of this manual.*

Reassembly of Sleeve Bearing Motors (See Figure 5). All parts must be thoroughly cleaned with High-Flash Naphtha, mineral spirits or Stoddard Solvent and inspected prior to assembly. Particular attention should be paid to the following areas:

1. Bearing and Seal Journals

Any scratches or marks on these diameters are not acceptable and must be "polished" out.

2. Bearing Housings

Thoroughly clean (use solvent as noted above) the inside of the bearing housing and inspect for foreign particles. Any traces of dirt, chips, loose paint, sand, etc. are not acceptable and must be removed.

3. Bearing

Inspect the bearing babbitt bore surface for any unusual or excessive wear patterns, imbedded dirt or distinct scratches. Bearings so damaged should be repaired or replaced (see **Section XII. Sleeve Bearing Replacement**). If any insulated bearing is provided, ensure that the insulating coating on the O.D. is not damaged.

4. O-Ring Seals on Bushing

Inspect for any damaged area. O-Rings that are damaged must be replaced.

To reassemble motor, reverse procedure for disassembly as outlined in **Section IX Disassembly**. Coat O-Ring Seals with silicone grease prior to assembling bushing on shaft. Coat the shaft bearing journals, bearing surfaces and spherical seat surfaces with oil (Tables 3 and 4 for proper oil) prior to assembly. The drive-end bearing has axial babbitted thrust faces on both inboard and outboard sides. If a single insulated bearing is provided, it should be installed on the opposite drive end of motor. When installing the bearing cap, coat its mating surface and the mating surface of the bracket with Permatex #2 or an equivalent non-hardening sealant.

A minimum gap of 0.004" (verified by feeler gauge) is to be provided all around between the seals and shaft to prevent rub. Check clearance and reposition seals as required.

When motor is fully assembled and housings have been filled with proper oil (see Table 4) turn the shaft by hand and check for free rotation. Oil rings should be viewed at this time to check for free rotation.

XI. SLEEVE BEARING INSPECTION

Many sleeve bearing motors are supplied with some type of bearing temperature detector and/or relay. These devices will provide a warning or shutdown of the equipment if bearings are overheating. The maximum safe operating temperature for most bearings is 90° C (194°F) at the babbitt. For an insulated bearing, the temperature detector or relay probe shaft is made from a non-conducting material to prevent an electrical path from the bearing to ground. Do not alter a bearing temperature detector or relay probe for the above reason.





Overheating of a bearing may be caused by one or more of the following factors:

1. Improper oil level (too low or too high).
2. Dirty oil or oil of the wrong type.
3. Failure of oil rings to rotate (binding).
4. Oil ring guides not adjusted properly.
5. Bent shaft.
6. Rough bearing surfaces due to corrosion or careless handling.
7. Thrust from driven equipment (usually due to improper coupling selection).
8. Poor alignment to driven equipment.
9. Excessive loading or cycling.
10. Insufficient bearing clearance.
11. Insufficient cooling air flow (air intake restricted or incorrect rotation direction).
12. Excessively high ambient temperature.

A bearing which overheats should be carefully inspected and corrective action taken to resolve the problem. Bearings may be removed by following the instructions in Section XII. Sleeve Bearing Replacement.

XII. SLEEVE BEARING REPLACEMENT

1. Bearings may be removed by following procedure in **Section IX. Disassembly.**
2. Clean and inspect all parts thoroughly, taking precautions noted in **Section X. Reassembly.**
3. Remove the oil ring guides and screws on the old bearings and set aside for use on replacement bearings.
4. For replacement bearings contact a U.S. Electrical Motors Service Center.
5. Install the oil ring guides onto the replacement bearings and adjust by bending at "X" to obtain dimension shown in Figure 6.
6. When installing the replacement bearings, note that the drive-end bearing has axial thrust faces on both the inboard and outboard sides.
7. For reassembly, follow procedures in **Section X. Reassembly.**

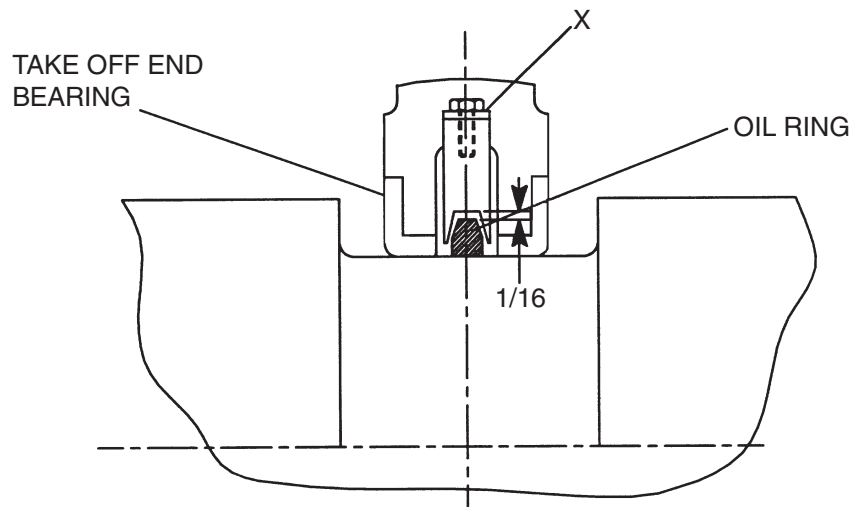

Figure 6 - Oil Ring Adjustment





XIII. LUBRICATION

Motor must be at rest and electrical controls should be locked open to prevent energizing while motor is being serviced (Refer to section on Safety, page i). If motor is being taken out of storage, refer to **Section III. "Storage", Part 4**, for preparation instructions.

Use a premium quality turbine oil from Table 4 which is fully inhibited against oxidation and corrosion.

Oil is added to a bearing by pouring through the oil fill hole at the top of each bearing housing. Add oil until the oil level reaches the "maximum" mark located on the oil sight gauge window. See the motor nameplate for the approximate quantity of oil required.

Table 3: Recommended Oil Specification for Sleeve Bearing Motors

Ambient Starting and Operating Temperatures Range (°F)	Shaft Speed RPM's	Viscosity Grades ◆◆	Lubrication Interval
Below 50°	All	May require heaters for start-up. Refer to USEM Engineering for exact requirements	
50° - 104°	Above 1800	ISO 32 Min. Viscosity index = 90	5,000 Hours or 1 Year◆ (Whichever comes first)
	1800 and below	ISO 68 Min. Viscosity index = 90	1 Year◆
Above 104°	All	Consult USEM Engineering for requirement	

◆ Frequent starting and stopping, damp or duty environment, extreme temperature, or any other severe service conditions, will warrant more frequent oil changes. If there is any question, consult USEM Engineering for recommended oil change intervals regarding your particular situation.

◆◆ Use Viscosity range noted unless lubrication plate on motor indicates otherwise.

Table 4: U.S. Motors Approved Oils for Sleeve Bearing Motors

Oil Manufacturer	ISO VG 32		ISO VG 68	
	Viscosity: 130-165 SSU at 100 F		Viscosity: 284-347 SSU at 100F	
	MINERAL BASE OIL	SYNTHETIC BASE OIL	MINERAL BASE OIL	SYNTHETIC BASE OIL
Chevron USA, Inc.	GST Turbine Oil 32	Tegra 32	GST Turbine Oil 68	Tegra 68
Conoco Oil Co.	Hydroclear Turbine Oil 32	Syncon 32	Hydroclear Turbine Oil 68	Syncon 68
Exxon Co., USA	Teresstic 32	Synnestic 32	Teresstic 68	Synnestic 68
Mobil Oil Co.	DTE Oil Light	SHC 624	DTE Oil Heavy Medium	SHC 626
Pennzoil Co., Inc.	Pennzbell TO 32	Pennzbell SHD 32	Pennzbell TO 68	Pennzbell SHD 68
Phillips Petroleum Co.	Magnus 32	Syndustrial "E" 32	Magnus 68	Syndustrial "E" 68
Shell Oil Co.	Tellus 32	Tellus HD Oil AW SHF 32	Tellus 68	Tellus HD Oil AW SHF 68
Texaco Lubricants Co.	Regal 32	Cetus PAO 32	Regal 68	Cetus PAO 68





**TABLE 5
RECOMMENDED FASTENER TORQUE VALUES**

Fastener Size	Torque* (Ft.- Lbs.)
1/4 - 20 UNC	8
5/16 - 18 UNC	17
3/8 - 16 UNC	30
7/16 - 14 UNC	50
1/2 - 13 UNC	75
9/16 - 12 UNC	110
5/8 - 11 UNC	150
3/4 - 10 UNC	260
7/8 - 9 UNC	430
1 - 8 UNC	640
1-1/8 - 7 UNC	800
1-1/4 - 7 UNC	1120
1-3/8 - 6 UNC	1460
1-1/2 - 6 UNC	1940

*Based upon using a dry (unlubricated) Grade 5 fastener

XIV. RENEWAL PARTS AND SERVICE

Parts lists for specific units can be furnished upon request. Parts may be obtained from local U.S. Motors distributors and authorized service shops, or via the U.S. Motors Distribution Center to ensure a prompt, accurate response. You should obtain all of the pertinent information from the motor nameplate. This information should include the motor model number and serial number, the horsepower speed motor type and frame size.

U.S. ELECTRICAL MOTORS DISTRIBUTION CENTER
3363 MIAC COVE
MEMPHIS, TN 38118
PHONE (901) 794-5500
FAX (901) 366-4225

**TABLE 6
MAXIMUM MOTOR WEIGHTS**

FRAME	ODP/WPI	WP11
5006	3500 lbs.	3800 lbs.
5008	4100 lbs.	4400 lbs.
5010	4800 lbs.	5100 lbs.
5012	5500 lbs.	5800 lbs.
5810	5400 lbs.	6300 lbs.
5811	6300 lbs.	7200 lbs.
5812	7500 lbs.	8400 lbs.
5813	8600 lbs.	9500 lbs.





FIGURE 7A

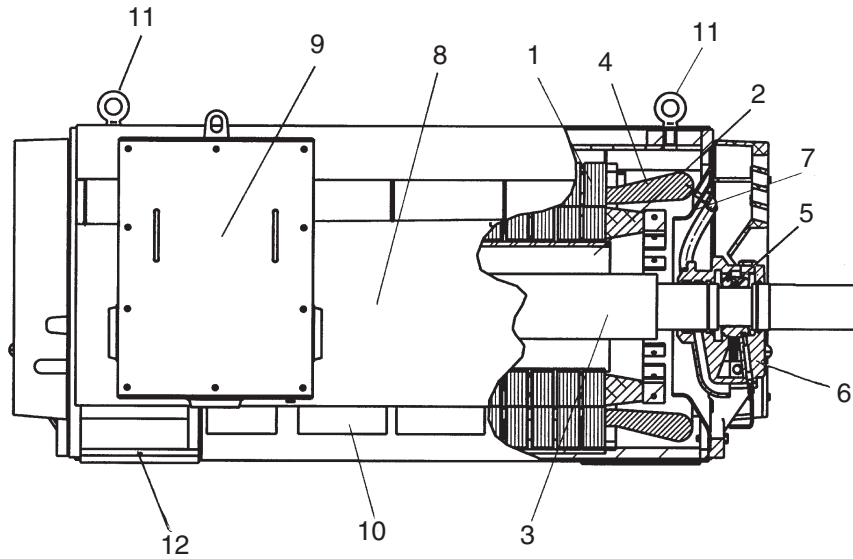

1. Stator
2. Rotor
3. Shaft
4. Stator Coils
5. Bearing
6. Bearing Bracket
7. Air Deflector
8. Stator Housing (Frame)
9. Terminal Box
10. Ventilation Baffles
11. Motor Lifting Eyes
12. Dowel Pin Holes

ODP/WPI

FIGURE 7B

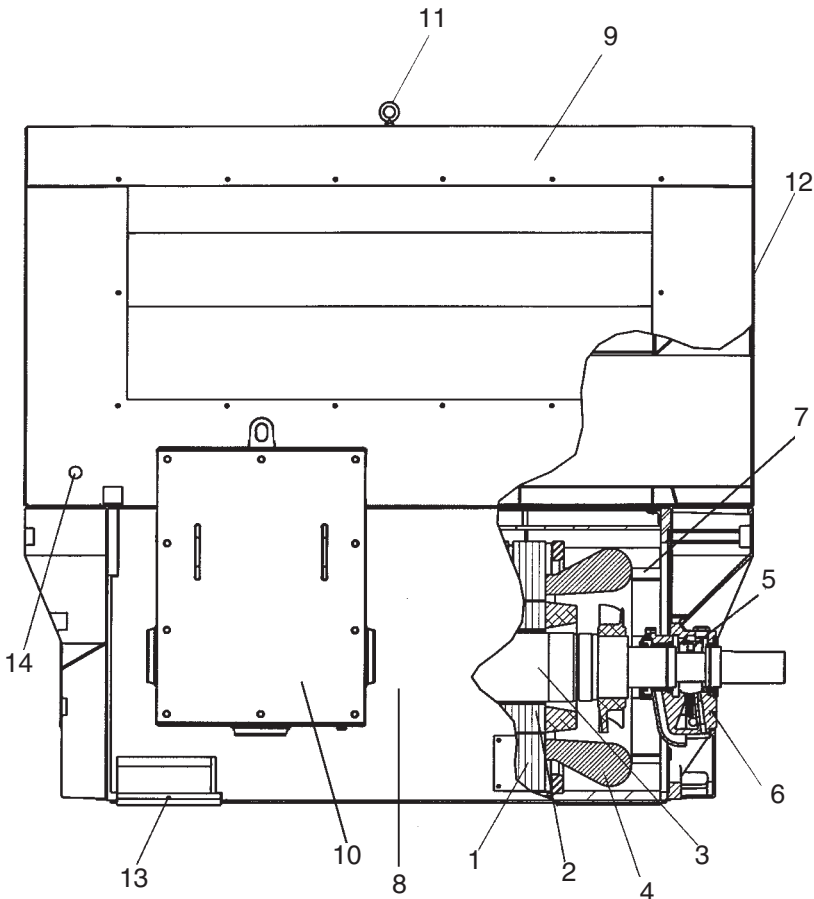

1. Stator
2. Rotor
3. Shaft
4. Stator Coils
5. Bearing
6. Bearing Bracket
7. Air Deflector
8. Stator Housing (Frame)
9. Tophat
10. Terminal Box
11. Tophat Lifting Eye
12. Air Filter Access Cover
13. Dowel Pin Holes
14. Air Pressure Differential Port

WPII





XV. TROUBLESHOOTING

TROUBLE	POSSIBLE CAUSE	CORRECTION
Motor will not start	Does not rotate. Usually line trouble single phasing at starter.	Check source of power supply. See Safety instructions! Check overloads, controls and fuses. Check voltage, compare with nameplate voltage.
	Rotates but does not come up to speed. Load too heavy.	Disconnect motor from load to verify if motor starts without load. Reduce load-or replace motor with motor of greater load capacity.
Excessive motor humming	High voltage	Check input voltage and proper motor lead connection.
Noise	Unbalanced rotor	Balance rotor assembly.
Clicking	Contaminants in air gap	Remove rotor assembly and clean motor.
Vibration	Misalignment in coupling or feet	Realign motor per initial installation section.
	Vibration in driven equipment	Disconnect motor from driven equipment. See section on safety. Run motor unconnected and check vibration. If vibration drops dramatically, then the driven equipment or alignment may be the cause of vibration.
	Ambient Vibration	Check base vibration level with motor stopped.
	System natural frequency (resonance)	Revise rigidity of motor base structure.
Vibration (following motor repair)	Rotor out of balance; balance weights or fans shifted on rotor.	Balance rotor assembly.
Motor overheating (Check with thermocouple or by resistance methods - do not depend on hand)	Overload	Measure load; compare with nameplate rating; check for excessive friction in motor or complete drive. Reduce load or replace motor with greater capacity motor.
	Dirt in motor intake or exhaust openings	Clean motor intake and exhaust areas. Clean filters or screens if motor is so equipped. See safety section.
	Unbalanced voltage	Check voltage, all phases.
	Open stator windings	Disconnect motor from load. Check idle amps for balance in all three phases. Check stator resistance in all three phases for balance. See safety section.
	Over / under voltage	Check voltage and compare to nameplate voltage.
	Ground	Locate with test lamp or insulation tester and repair.
	Improper connections	Recheck connections.





TROUBLE	POSSIBLE CAUSE	CORRECTION
Fine dust under coupling with rubber buffers or pins	Misalignment	Realign couplings, inspect couplings. See initial installation section.
Bearing overheating	Misalignment	Realign unit. See initial installation section.
	Incorrect Lubricant	Refill with approved lubricant.
	Axial Thrust	Coupling must be limited end float type to eliminate thrust on motor. See Initial Installation section for coupling requirements.
Foaming Oil	Incorrect Lubricant	Refill with approved lubricant.





U.S. ELECTRICAL MOTORS INSTALLATION AND MAINTENANCE

Installation Record

XVI. INSTALLATION RECORD

NAMEPLATE ID # _____ CUSTOMER ID # _____

FRAME _____ TYPE _____ HORSEPOWER _____ RPM _____ VOLTAGE _____

PHASE _____ FREQUENCY _____ AMPS _____ DESIGN _____ CODE _____

DATE OF PURCHASE _____ DATE INSTALLED _____

PURCHASED FROM _____

LOCATION OF MOTOR _____ INSTALLATION # _____

DRIVE END BEARING # _____ OPPOSITE END BEARING # _____

MOTOR RESISTANCE LINE TO LINE AT TIME OF INSTALLATION _____

INSULATION TO GROUND READING AT TIME OF INSTALLATION _____

GRADE & TYPE OF LUBRICANT USED _____

INSPECTION RECORD

DATE CHECKED							
Bearings							
Lubrication							
Excess Heat							
Excess Noise							
Speed							
Voltage							
Amps							
Insulation							
Cleaning							
Alignment							
Vibration							
Temperature							
Insul. Resistance							
Condition							



VISIT OUR WEB SITE

**www.
usmotors
.com**

**...access an electronic copy of this catalog,
print a product's installation/maintenance
manual and find an authorized service
station near you.**

... 24 hours a day, 7 days a week



U.S. ELECTRICAL MOTORS DIVISION
Emerson Electric Co.
8100 West Florissant Avenue
St. Louis, MO 63136

REGIONAL OFFICES

PHONE

FAX

ORANGE, CONNECTICUT	(800) 243-2700	(203) 891-1077
CHICAGO, ILLINOIS	(800) 323-5223	(630) 893-0182
MEMPHIS, TENNESSEE	(901) 794-5500	(901) 366-2661
DALLAS, TEXAS	(800) 683-4126	(972) 644-0254
SANTA FE SPRINGS, CALIFORNIA	(800) 854-3302	(562) 941-1858
INTERNATIONAL SALES	(314) 553-2196	(314) 553-2135



REGIONAL OFFICES

PHONE

FAX

MONTREAL, QUEBEC/CANADA	(800) 361-5509	(514) 332-5912
TORONTO, ONTARIO/CANADA	(905) 475-4670	(905) 475-4672
MONTERREY, MEXICO	(52)8-389-1300	(52)8-389-1310
CARACAS, VENEZUELA	(58)2-237-7522	(58)2-232-9727
BOGOTA, COLOMBIA	(57)1-439-5420	(57)1-439-5417



WWWHome Page: <http://www.usmotors.com>
E-Mail: uselectrical.motors@industry.com
Literature Hotline: 800-665-4850